

# EBU 18 - EBU 50

Waste bin with removable thrown-in frame, stainless steel (AFP) or powder-coated, 18 liter or 50 liter

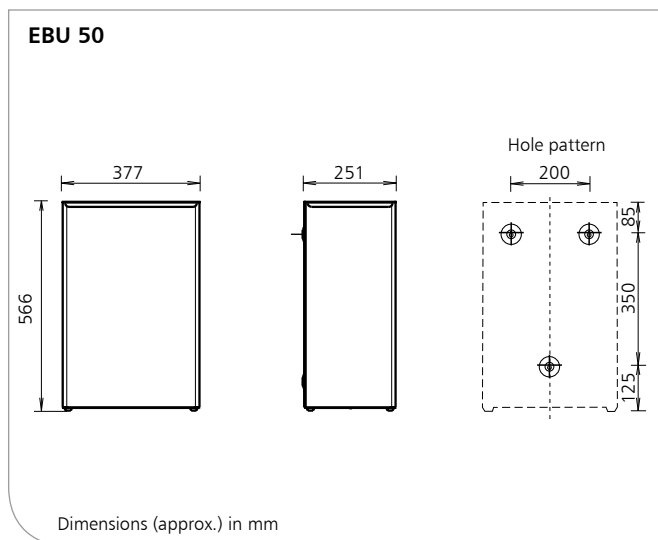
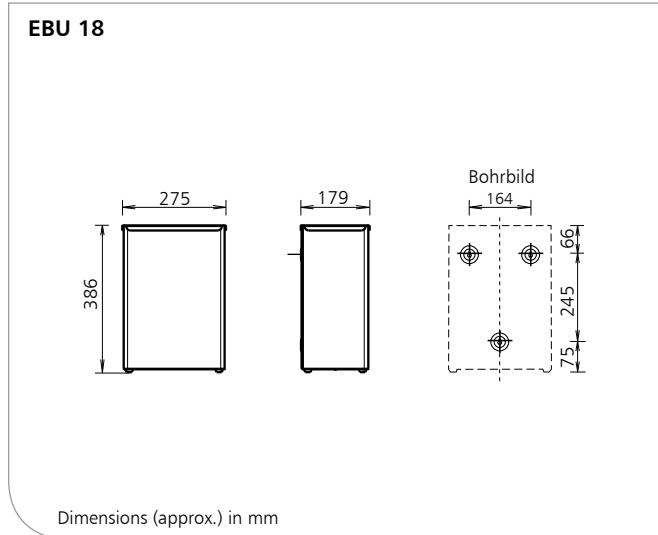

**Product characteristics**

- ▶ Waste bin with internal bag holder for hidden fastening of the waste bag
- ▶ High-quality and robust stainless steel housing
- ▶ With throw-in frame
- ▶ For wall-mounting or free-standing
- ▶ Throw-in frame can be removed to replace the waste bag
- ▶ Incl. mounting kit for three-point wall mounting

**Interesting information**

References:

- ▶ Conference centres, exhibitions, airports, train stations, catering, retirement/care homes, hospitals, laboratories, commercial kitchen, food processing, industry, shopping centres, hotels, correctional facilities, schools, kindergartens, sports centres, administration facilities

Application examples:

- ▶ Washrooms, toilets, baths, care and examination rooms, kitchens, entrance areas

**Technical data**

Housing:

Stainless steel AISI 304, brushed with Anti-Fingerprint Coating (E AFP) or powder-coated white (RAL 9010)

Capacity:

18 liter (EBU 18), 50 liter (EBU 50)

Wall mounting:

Wall mounting with 3 screws and wall plugs

**Description for tender - see overleaf**

EBU 18 - EBU 50/0120/1.3



Subject to technical modifications.



**Ophardt Hygiene-Technik GmbH + Co. KG**

Lindenau 27 | 47661 Issum | Germany

Tel.: +49 (0) 28 35 18-10 | Fax +49 (0) 28 35 18-77

planer@ophardt.com | www.ophardt.com

# EBU 18 - EBU 50

Waste bin with removable thrown-in frame, stainless steel (AFP) or powder-coated, 18 liter or 50 liter

## Description for tender EBU 18

... Pcs. **SanTRAL® EBU 18 E** Art. No. 1423042  
Waste bin, 18 liter, made from brushed stainless steel with Ophardt Hygiene Anti-Fingerprint Coating (AFP), removable throw-in frame, internal bag holder, for wall-mounting and free-standing  
Dimensions (W x H x D) 275 x 386 x 179 mm

... Pcs. **SanTRAL® EBU 18 P** Art. No. 1423053  
Waste bin, 18 liter, white (RAL 9010) powder-coated stainless steel, removable throw-in frame, internal bag holder, for wall-mounting and free-standing  
Dimensions (W x H x D) 275 x 386 x 179 mm

## Description for tender EBU 50

... Pcs. **SanTRAL® EBU 50 E** Art. No. 1413896  
Waste bin, 50 liter, made from brushed stainless steel with Ophardt Hygiene Anti-Fingerprint Coating (AFP), removable throw-in frame, internal bag holder, for wall-mounting and free-standing  
Dimensions (W x H x D) 377 x 566 x 251 mm

... Pcs. **SanTRAL® EBU 50 P** Art. No. 1413895  
Waste bin, 50 liter, white (RAL 9010) powder-coated stainless steel, removable throw-in frame, internal bag holder, for wall-mounting and free-standing  
Dimensions (W x H x D) 377 x 566 x 251 mm

Product: **SanTRAL®**  
Manufacturer: OPHARDT HYGIENE-TECHNIK GmbH + Co. KG

## Compatible accessories

- ▶ EBU 18: PB 2, grey plastic bags, 4x50 pcs., Art. No. 506100
- ▶ EBU 50: PB 4, white plastic bags, 200 pcs., Art. No. 128100